



ADDENDUM No. 2

Date: June 4, 2026

Project: Grand Forks International Airport
Reconstruct Runway 17R/35L – South & Middle Portion

Bid Date and Time: June 10, 2026, 10:00 AM local time

This addendum is hereby made a part of the contract documents identified Reconstruct Runway 17R/35L – South & Middle Portion, Grand Forks International Airport, Grand Forks, North Dakota, to the same extent as though it were originally included therein. It is essential that prospective bidders note the contents of this addendum and that the Grand Forks Regional Airport Authority be made aware that the addendum has been received. Therefore, acknowledge receipt by inserting the number of this addendum in the space provided on the Contract Proposal.

SIGNIFICANT CHANGES ARE THE FOLLOWING

- 1.) Issue new Sheet E-615. Changes include:
 - a. The Engineer was recently made aware of difficulty obtaining the originally-specified 10’ segments for the Segmented Circle and Traffic Pattern Indicators. The layout shown on Sheet E-611 (with 10’ segments) is preferred, but if the Contractor is unable to obtain 10’ segments, the layout shown on the new Sheet E-615 (with 8’ segments) is acceptable.
- 2.) Attach Bidder Questions received as of 06/03/2026.

PLANS

1. Sheet E-615 – Electrical Details – Addendum 2

- A. Issue new sheet.
- B. Changes include:
 - I. Included new layout for Segmented Circle and Traffic Pattern Indicators if the Contractor is only able to obtain 8' segments.

ATTACHMENTS

- 1. New Plan Sheets – as listed
- 2. Bidder's Questions to date

END OF ADDENDUM 2

THE ENGINEER WAS RECENTLY MADE AWARE OF DIFFICULTY FINDING THE ORIGINALLY-SPECIFIED 10' SEGMENTS FOR THE SEGMENTED CIRCLE. THE LAYOUT SHOWN ON SHEET E-611 (WITH 10' SEGMENTS) IS PREFERRED, BUT IF THE CONTRACTOR IS UNABLE TO OBTAIN 10' SEGMENTS, THE LAYOUT DETAILED ON THIS SHEET (WITH 8' SEGMENTS) IS ACCEPTABLE.

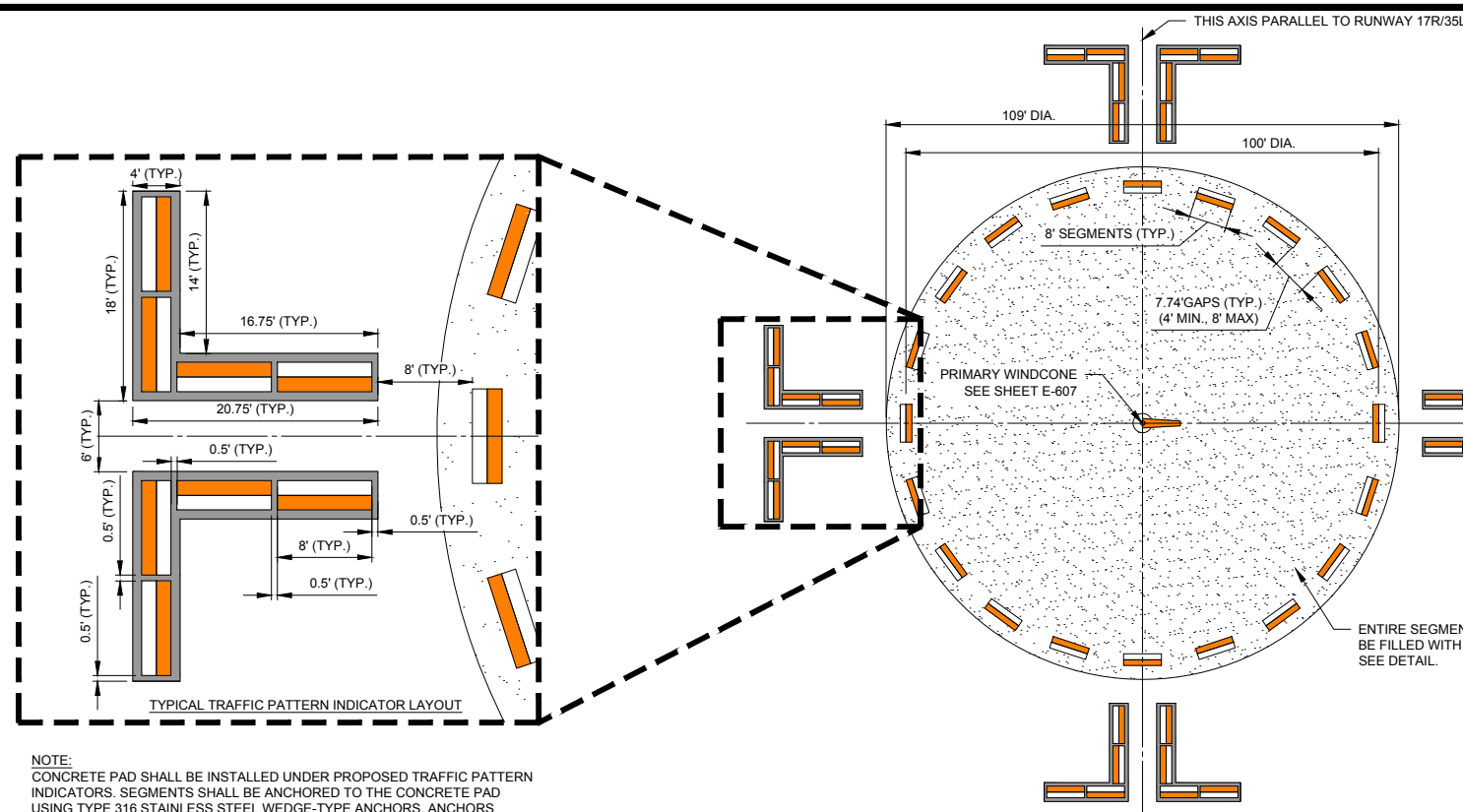

1 SEGMENTED CIRCLE MARKER AND PRIMARY WINDCONE LAYOUT
NO SCALE

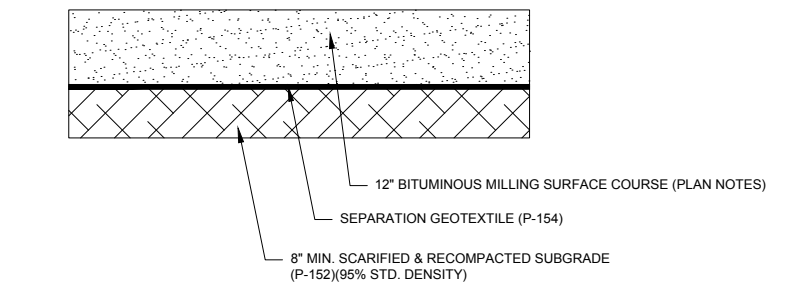

2 SEGMENTED CIRCLE GRAVEL SECTION
NO SCALE

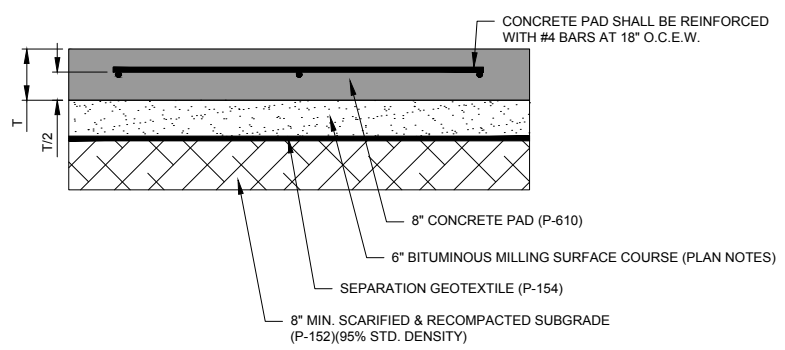

3 TRAFFIC PATTERN INDICATOR CONCRETE PAD SECTION
NO SCALE

NOTE:
CONCRETE PAD SHALL BE INSTALLED UNDER PROPOSED TRAFFIC PATTERN INDICATORS. SEGMENTS SHALL BE ANCHORED TO THE CONCRETE PAD USING TYPE 316 STAINLESS STEEL WEDGE-TYPE ANCHORS. ANCHORS SHALL HAVE A MINIMUM DIAMETER OF 1/2\" AND A MINIMUM EMBEDMENT DEPTH OF 4\".

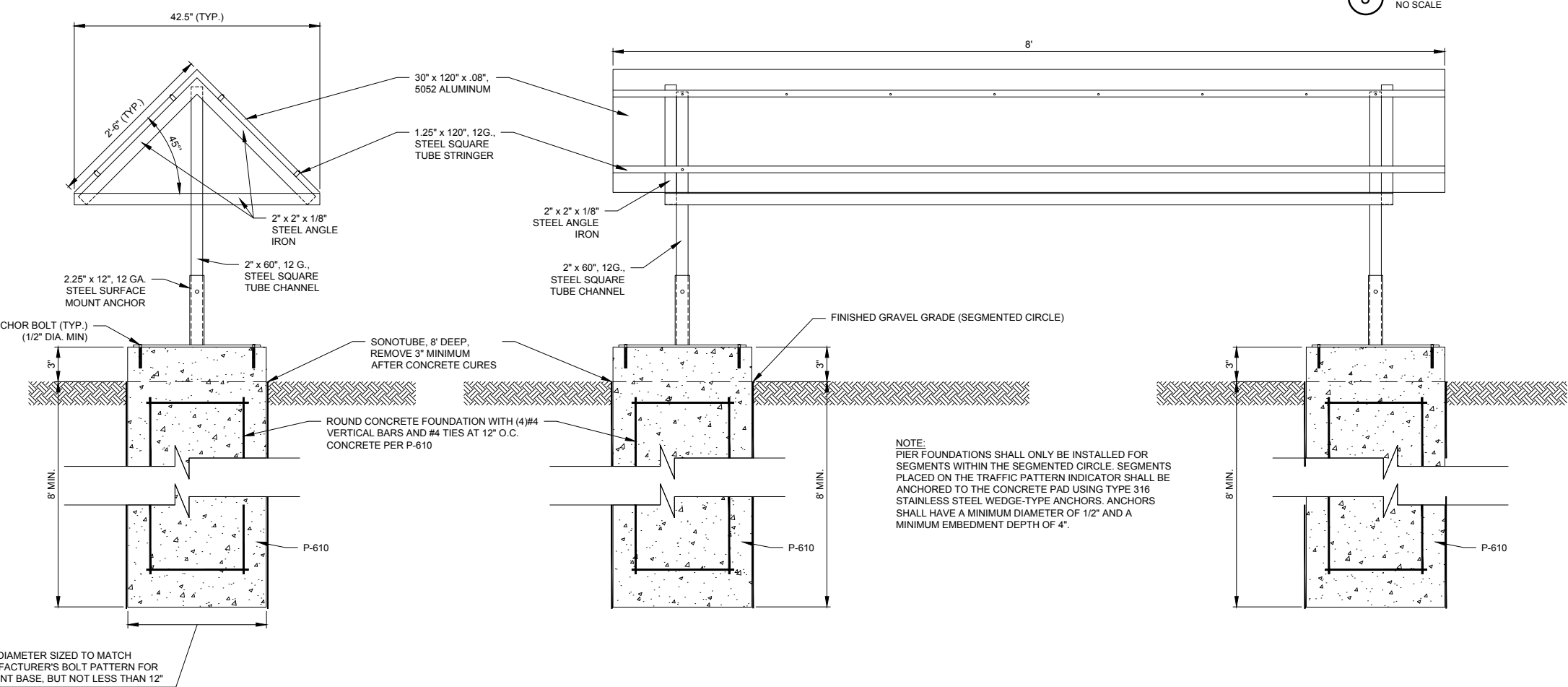

4 SEGMENTED CIRCLE - SEGMENT SIDE VIEW
NO SCALE

NOTE:
PIER FOUNDATIONS SHALL ONLY BE INSTALLED FOR SEGMENTS WITHIN THE SEGMENTED CIRCLE. SEGMENTS PLACED ON THE TRAFFIC PATTERN INDICATOR SHALL BE ANCHORED TO THE CONCRETE PAD USING TYPE 316 STAINLESS STEEL WEDGE-TYPE ANCHORS. ANCHORS SHALL HAVE A MINIMUM DIAMETER OF 1/2\" AND A MINIMUM EMBEDMENT DEPTH OF 4\".

5 SEGMENTED CIRCLE - SEGMENT FRONT VIEW
NO SCALE



Bidder Questions Answered by the Engineer

1. Question:

want to make sure I am understanding correct, we can either bid the electrical separate or to a prime?

Response:

Yes, you are correct. If Electrical Contractors want to bid as an electrical prime, they can just fill out Bid Schedule 2 and Bid Alternate 1B. Otherwise, they are free to coordinate with a general/civil prime who can include the prices in their Bid Schedule 3/Bid Alternate 1C.

2. Question:

Reading the specs it sounds like all conduit shall be PVC except the HDPE for boring? Which I am then assuming it all needs to be open trenched with clean backfill?

Response:

HDPE conduit will be allowable meeting NEC requirements and UL Listings. All joints, couplers and accessories are to be listed for HDPE use. Plowing in HDPE conduit to be allowable in single conduit run installation along runway edge of pavement. All open trenching to be backfilled per project specifications and project details. Ensure measures are implemented during installation to prevent the HDPE conduit coiling back upward.

3. Question:

I am wondering about the lack of bid items for Contractor quality control program and Temporary erosion control for the Bid Alternate. Will they be added by addendum?

Response:

These items will be added to the Bid Alternate bid schedules with Addendum 1.

4. Question:

C-001 has notes about the bituminous milling surface course. The bituminous milling surface course item is in Division 3, gravel service road. The notes talk about bituminous millings salvaged from the removal of pavement on the project/taken from other areas of the project. It requires them to meet a gradation and requires the contractor to sample and test for gradation on each day of milling. It's my understanding that the gravel service road is built before the project starts using existing millings stockpiled on the airport property. If we are using millings from an existing stockpile, we're stuck with the gradation of the material in the pile. Am I understanding this correctly?

Response:

That is incorrect. The first portion of the gravel service road (from the ARFF Training Ground to the FAA SWS site) is to be constructed with virgin aggregate material. This will allow access to the Runway to begin milling operations. The remainder of the road will be constructed with the millings removed from the Runway.

5. Question:

C-001 also has notes about the crushed stone backfill. The crushed stone backfill is in Alternate 1A - Division 9, taxiways. What is this used for? Daily gradations are required. Is this imported or processed from onsite materials?

Response:

Please refer to the Typical Sections on Sheets C-309 and C-310. Crushed stone backfill is to be used in place of the cement-treated subgrade in areas with short construction durations – like the connections to Taxiway A and the revisions to the Taxiway B fillets. This material is to be imported.

6. Question:

The CSPP sheets for the alternate have a 20' height restriction. The CSPP sheets for the base bid have 50' and 30' limits. Does the 20' height limitation apply to all the area shown on G-086 to G-089 or only the work area added by the alternate, IE the middle portion of the runway?

Response:

This height is incorrect. This will be corrected with Addendum 1. The heights for the Bid Alternate should be 50 feet for all phases.

7. Question:

The seeding limits on parts of the service road are very narrow, as narrow as 1'. If a wider area is disturbed building or backfilling the road, and wider seeding is required, is that work paid for or incidental?

Response:

Seeding limits include only the areas included in the design surface. Restoration of any areas outside of the grading limits in considered incidental.

8. Question:

The notes describe salvaging bituminous material/millings from the project and blending them with virgin material to make subbase course. Just to clarify, the blended subbase course described is the P-154 subbase course that is under the runway and taxiways. Correct?

Response:

Contractor must ensure that they have enough millings to construct the gravel service road and the segmented circle as shown in the plans. Any excess millings may be blended with the subbase course under the Runway and Taxiways.

9. Question:

We were wondering if we could do a site drive through. Please let us know if this will be acceptable and if there is a site contact we should reach out to before arriving.

Response:

Getting out on the airfield will really depend on the weather. That portion of the Runway is heavily used, and if the winds are strong out of the north or south, it might be difficult to get out there due to the traffic. Please contact the airport if you wish to schedule a site visit, but be aware that scheduling may be difficult. The Airport contact for site visit is Joey Castiglione (jcastiglione@gfkairport.com).

10. Question:

Sheets C-906 and C-915 appear to be showing the wrong cross-sections. Can you provide an updated Sheet C-906 and C-915.

Response:

Corrected sheets will be included in Addendum 1.

11. Question:

Could I get a copy of the pre-bid meeting sign in sheet?

Response:

The sign-in sheet will be included with the Pre-Bid Meeting Minutes, which will be distributed with Addendum 1.

12. Question:

Jointing layout is set up with a 37.5' paving width. Is 37.5' pave width required?

Response:

Per note 3 on the Jointing Plan sheets, the paving width may be adjusted by the Contractor. If the Contractor elects to revise the paving width, the jointing layout and joint types shall be revised accordingly.

13. Question:

Is Coal Creek fly ash allowable?

Response:

Coal Creek flyash has been used successfully on past projects at GFK. Coal Creek flyash is allowable as long as it meets the P-501 Specifications for Loss on Ignition and Calcium Oxide content. Available Alkalies, as Na₂O_e shall be less than 3%.

14. Question:

I am struggling to find 10' segmented circle parts. Would it be an option to switch that to the 8' sections?

Response:

While 10' segments are preferred, the use of 8' segments is acceptable. If a Contractor uses 8' segments, the layout of the Segmented Circle and Traffic Pattern Indicators must be adjusted. An alternative layout for the Segmented Circle and Traffic Pattern Indicators, which uses 8' segments, will be included with Addendum #2.

15. Question:

Is an 18.75 paving lane acceptable?

Response:

Per note 3 on the Jointing Plan sheets, the paving width may be adjusted by the Contractor. If the Contractor elects to revise the paving width, the jointing layout and joint types shall be revised accordingly.

The Contractor should note that utilizing an 18.75' paving width will result in additional dowels. Longitudinal joints along Runway 17R/35L at 18.75' LT and 18.75' RT and along Taxiway A7 at 18.75' LT are currently designed as Type D (Dummy) joints as they are contraction joints that are more than 20' from a free edge. An 18.75' paving lane would result in these joints being construction joints, and Type E (Doweled Construction) joints would be required per FAA Advisory Circular 150/5320-6G, Table 3-5. The same would also be required on the longitudinal joints on the Blast Pad.